



Agricultural storage coolers THOR-F, TYR-F, LFX

Standard coolers with Cu or Stainless Steel tubing





Contents

	page
Model indication	2
Eurovent	2
Capacities	2
General information	3
Standard product configuration	3
Non standard executions	4
Fans	5
Correction factors & Selection example	6
Capacities & technical data	7
Defrost systems	8
Dimensions	9

Model indication

THOR-F / TYR-F / LFX

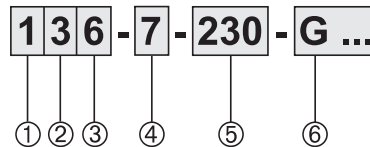

Pos.	Reference
1	Cooler module 1 and 2
2	Number of fans 3 - 8
3	Tube rows 6 tube rows in air direction
4	Fin spacing 7 mm
5	Current 400 = 230/400/50/3 230 = 230/50/1
6	Options For a full survey of all available options see page 4

Eurovent

Within Europe, a wide variety of published data on capacities are in use, generally depending on national standards. Most in use by the leading manufacturers are national and international standards like DIN, ENV, NEN-EN and ASHRAE. Due to this, customers have not been able to make objective product comparisons, since data published on capacities were based on DT₁, DTM, dry or wet conditions, with or without certification, etc.



To meet the European requirements on EN standards, the European Refrigeration Industry embodied by Eurovent has set standards to guarantee an independent certification procedure for forced convection air cooled condensers based on NEN-EN 327 and unit air coolers based on NEN-EN 328. Being an active member of Eurovent, the capacities of the Alfa Laval commercial cooler programme, as given in the technical documentation, are based on NEN-EN 328 (evaporating temperature $t_0 = -8\text{ °C}$, 8 K temperature difference between air-on temperature and evaporating temperature (DT₁)).

In order to enable air cooler selection for operating conditions, technical documentation should also give capacities for humid/frosted conditions. According to Eurovent these 'frosted conditions' are to be calculated by multiplying 'dry capacities' with a factor 1.15. These data can be found in the capacity tables, in the columns marked "frosted".

Capacities

Frosted conditions

- Lightly frosted coil.
- Relative humidity 85 %.
- Suction gas superheating 62% of the temperature difference (DT₁), with a minimum of 3.5 K.
- Refrigerant liquid temperature 30 °C

Evaporating temperature t_0

Evaporating temperature t_0 is the saturated temperature according to the pressure at the suction outlet of the cooler.

Dry conditions

Cooling capacity where no condensation or ice build-up occurs on the coil (100% sensible cooling). This condition is used by Eurovent to standardise capacity ratings but should not be used when selecting coolers. For cooler selection use the columns marked "frosted".

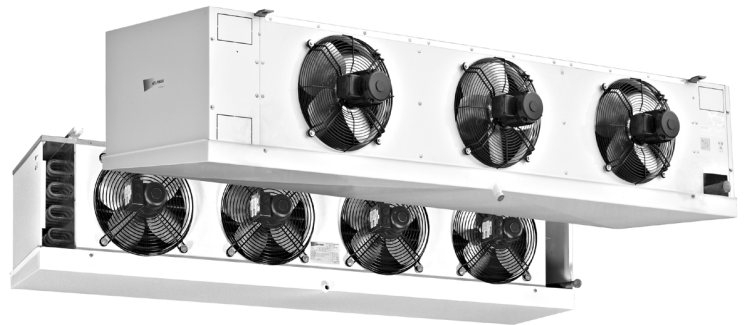

General Information

Air cooler models THOR-F, TYR-F and LFX have been specially designed for the refrigerated storage of agricultural produce. These cooler models are characterised by an optimised capacity/air volume ratio and a relatively low profile. All models have been optimised for air temperatures around 0 °C and a small temperature difference to avoid product dehydration.

Application area: evaporating temperatures of +5 down to -10 °C using either halogen refrigerants, CO₂, ammonia (TYR-F only) or secondary refrigerants.

Capacities (Eurovent SC 2) 7 up to 57 kW.

Air flow 5,100 up to 36,000 m³/h.

Other THOR & TYR models

THOR & TYR

Wide and flexible ranges of industrial air coolers fitted with blow-through or draw-through fans. All models have been highly standardised in construction and dimensions, while maintaining flexibility in fin spacings, coil construction and circuiting design.



THOR-A & TYR-A

For airsock application Alfa Laval has developed a special airsock cooler range. These models are fitted with an airsock ring and fan motors capable of supplying the extra external pressure that is required for the proper functioning of air-socks.



THOR-D & TYR-D

Low silhouette dual discharge air coolers.



Two-Year Guarantee

Because Alfa Laval has the fullest confidence in the product quality, a two-year full guarantee is given.

Product Configuration THOR-F & TYR-F

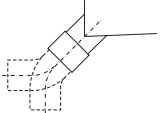
- Finned coil
 - 2 coil block modules
 - 6 tube rows deep
 - THOR-F Cu ripple fin tubing ø 5/8" (smooth tubing for brine)
 - TYR-F Stainless steel tubing ø 16 mm
 - Tube pitch 50 x 50 mm square
 - Corrugated Alu-fins
 - Fin spacing 7 mm.
- 3-7 Fans, blowing through the coil, available in a range of different executions. Fans with elevated external pressure to ensure optimized air distribution. Diameters Ø 406 mm or Ø 457 mm. Fan motor protection class IP55.
- Corrosion resistant casing material: Aluminium/Sendzimir, white epoxy coated (RAL 9003).
- Hinged, enclosed end covers.
- Hinged dripray. Drain(s) 32 mm PVC connection, freely adjustable into either horizontal or vertical position.
 
- Refrigerant distribution optimised to refrigerant applied.
- Refrigerant connections on right hand side (fan side view).
- Fitted with schröder valve on the suction connection for testing purposes (not for R-717).
- Sufficient room for fitting the expansion valve inside.
- Suitable for dry expansion or pumped system. TYR-F only: DX-coolers for halogen refrigerants are fitted with Cu-distributor.
- Stickers indicate fan direction and refrigerant in/out.
- Delivery in mounting position. Coolers are mounted on wooden beams. Installation can take place with use of a forklift.
- Design pressure 33 bar (H(C)FC), 27 bar (ammonia) or 6 bar (brine). Higher design pressures on request. Each heat exchanger is leak tested with dry air and finally supplied with a nitrogen pre-charge.



Product Configuration LFX

- Finned coil
 - 2 coil block modules
 - 6 tube rows deep
 - Cu tubing ½", wall thickness 0.4 mm
 - Tube pitch 38 x 38 mm square
 - Alu-fins, thickness 0.35 mm
 - Fin spacing 7 mm.
- 3-8 Fans, blowing through the coil, available in a range of different executions. Fans with elevated external pressure to ensure optimized air distribution. Diameters Ø 305 mm or Ø 356 mm. Fan motor protection class IP55.
- Corrosion resistant casing material: Aluminium/Senzimir, white epoxy coated (RAL 9003).
- Hinged (module 1) or easily removable (module 2) end covers.
- Easily removable driptray. Horizontal drain(s) G 1" ext.
- Refrigerant distribution optimised to refrigerant applied.
- Refrigerant connections on right hand side (fan side view).
- Fitted with schröder valve on the suction connection for testing purposes.
- Sufficient room for fitting the expansion valve inside.
- Suitable for dry expansion or pumped system.
- Stickers indicate fan direction and refrigerant in/out.
- Delivery in mounting position. LFX models module 1 in wooden crate, module 2 mounted on wooden beams. Installation can take place with use of a forklift.
- Design pressure 33 bar (H(C)FC) or 6 bar (brine). Higher design pressures on request. Each heat exchanger is leak tested with dry air and finally supplied with a nitrogen pre-charge.

Options (all models)

- Defrost systems
 - Hot gas coil in driptray G1
 - Electric defrost E1, E4
 - Water defrost W

Electric defrost for air coolers with pumped refrigerant circulation or in glycol execution on special request only.

- Driptray insulation
 - Styropore 10 mm + cladding I2
 - Foamglass 25 mm + cladding I3

- Refrigerant connections left (fan side view) L



- Isolating switch ISM

- Secondary refrigerant

Air coolers for secondary refrigerant application can be selected with our selection software. Extra information on request.

- Stainless steel 304 casing SSC

- Fan motors 400/60/3 or 230/60/1

Non-standard executions *(on request only)*

- Higher capacities
- Special fan motors:
 - Dual fan speed motors
 - Variable fan speed motors
 - EC fans
 - Alternative electrical supply 460/60/3
- Built in heater coil sections



Fans

Execution

Fans are executed with balanced aluminium or polyamide fan blades, fitted with robust electrolytically galvanized and epoxy coated fan guards according to DIN 31001. Fans are mounted in vibration dampers.

Enclosed design spray-tight motors, protection class IP-55.

All motors are equipped with a thermal safety device built in the windings, connected to separate terminals in the box. This safety device can therefore be integrated into the control circuit. The electrical control should be arranged preferably with a manual reset device in order to prevent continuous on/off switching (tripping) of the motors. Cable inlet ranges from 7 up to 12 mm.

Air throw

Air throws as given in the tables are for ceiling mounted coolers at $t = 20\text{ °C}$, an unrestrained air flow in the cold room and a minimal air velocity of 0.25 m/s at air throw distance.

Sound pressure dB(A)

Sound pressure as given in the tables are sound pressure levels in dB(A) according to EN 13487 at 5 m distance in free field conditions. Values may deviate depending on situations at site. The table below gives calculated sound pressure corrections at various distances.

Distance m	Correction dB(A)
1	+ 14
2	+ 8
3	+ 4
4	+ 2
5	0
10	- 6
20	-12
50	-20

Fans 50 Hz

Fan motor W	Motor voltage* V	Electric capacity		Adj. values overload relays A 0 °C	Cable inlet
		nom. kW	abs. kW**		
90	230/400/3	0.09	0.19	0.5	2 x M20 x 1.5
70	230/1	0.07	0.19	1.3	2 x M20 x 1.5
250	230/400/3	0.25	0.37	1.1	2 x M20 x 1.5
220	230/1	0.22	0.37	2.6	2 x M20 x 1.5

* Motor windings 230 Volt.

** These 230/50/1 motors are suitable for temperatures down to -20 °C and are not provided with a thermal safety device in the windings.

Agricultural storage coolers

Selection Example DT₁

Refrigerant	R-404A dx
Selected fin spacing	7 mm
Tube material	Cu
Required cooling capacity	25 kW
Air-on temperature	+2 °C
Evaporating temperature	-5 °C

- 1) $DT_1 = +2 - (-5) = 7 \text{ K}$
- 2) Correction factor $DT_1 / R-404A : 1.13$
- 3) Multiply required capacity with correction factor : $25 \times 1.13 = 28.3 \text{ kW}$.
- 4) Cooler models can be selected in columns 'capacity / frosted' on page 7 with a nominal capacity of 28.3 kW.

For the above mentioned conditions the following models can be selected :

- LFX 286-7, nom. cap. 28.6 kW
- THOR-F 146-7, nom. cap. 27.1 kW
- THOR-F 156-7, nom. cap. 34.4 kW

Depending on parameters such as *air flow*, *number of fans* and *dimensions* (see tables) a final cooler model selection can take place.

Capacity values under 'dry conditions' are reference values for Eurovent conditions.

Standard condition SC	Air on temp. °C	Evaporating temperature °C	Factor dry/frosted
SC1	10	0	1.35
SC2	0	-8	1.15
SC3	-18	-25	1.05
SC4	-25	-31	1.01

SC 2 : Nominal capacity for cooling design.

Air-on temperature is the air temperature at the intake side of the coil block.

THOR-F, TYR-F, LFX

Correction factors

DT1 K	Evaporating temperature °C				
	5	0	-5	-8	-10
R-404A dx					
6	1.22	1.28	1.33		1.38
7	1.02	1.07	1.13		1.18
8	0.87	0.92	0.97	1.00	1.03
9	0.76	0.81	0.86		0.91
R-134a dx					
6	1.28	1.37	1.45		1.53
7	1.07	1.15	1.23		1.31
8	0.92	0.99	1.06		1.14
9	0.80	0.87	0.93		1.01
R-22 dx					
6	1.28	1.34	1.40		1.45
7	1.08	1.13	1.19		1.24
8	0.92	0.97	1.03		1.08
9	0.80	0.85	0.90		0.96
R-404A pumped system					
6	1.00	1.07	1.13		1.19
7	0.82	0.88	0.94		1.00
8	0.70	0.75	0.80		0.85
9	0.60	0.65	0.69		0.74
R-22 pumped system					
6	1.13	1.21	1.28		1.34
7	0.92	0.98	1.05		1.10
8	0.76	0.82	0.88		0.93
9	0.64	0.70	0.75		0.80
R-717 pumped system (ammonia)					
6	0.96	1.03	1.09	1.12	1.14
7	0.79	0.84	0.90	0.93	0.95
8	0.66	0.71	0.76	0.78	0.80
9	0.56	0.61	0.65	0.67	0.69

Correction factors for other refrigerants, alternative fin materials, coatings and optional coil block configurations on request.

Capacities R-404A

Cooler model	Capacities kW		Air flow m ³ /h	Coil surface m ²	Int. vol. dm ³	Weight kg	Dimensions		Fans			
	Frosted $t_0=-8^{\circ}\text{C}$ $DT_i=8\text{K}$	Dry cond. $t_0=-8^{\circ}\text{C}$ $DT_i=8\text{K}$					Length A mm	Height B mm	Cap. kW	Nr	Air throw (m)	Sound press. dB(A)
LFX												
LFX 136-7	6.8	5.9	5100	30.3	10	54	1600	450	90	3	12	54
LFX 146-7	9.6	8.3	6800	40.4	13	70	2040	450	90	4	12	56
LFX 156-7	11.6	10.1	8500	52.6	16	86	2560	450	90	5	12	57
LFX 166-7	14.3	12.4	10200	60.4	19	103	2900	450	90	6	12	58
LFX 246-7	14.7	12.8	11200	63.1	23	135	2660	540	90	4	15	59
LFX 256-7	19.9	17.3	14000	84.1	26	174	3420	540	90	5	15	60
LFX 266-7	22.2	19.3	16800	90.4	29	193	3640	540	90	6	15	61
LFX 276-7	25.9	22.5	19600	105.6	34	219	4190	540	90	7	15	61
LFX 286-7	28.6	24.9	22400	120.7	39	250	4740	540	90	8	15	62
THOR-F												
THOR-F 136-7	20.7	18.0	12840	101.4	32	159	2920	580	250	3	20	62
THOR-F 146-7	27.1	23.5	17130	135.2	42	203	3720	580	250	4	20	63
THOR-F 156-7	34.4	30.0	21410	169.0	53	246	4520	580	250	5	20	64
THOR-F 166-7	41.3	35.9	25690	202.8	63	290	5320	580	250	6	20	65
THOR-F 176-7	47.6	41.4	29970	236.6	74	333	6120	580	250	7	20	66
THOR-F 236-7	24.8	21.6	15410	121.7	42	176	2920	680	250	3	24	65
THOR-F 246-7	32.5	28.2	20550	162.2	53	225	3720	680	250	4	24	66
THOR-F 256-7	41.3	35.9	25690	202.8	65	274	4520	680	250	5	24	67
THOR-F 266-7	49.6	43.1	30830	243.4	76	323	5320	680	250	6	24	68
THOR-F 276-7	57.1	49.7	35970	283.9	88	372	6120	680	250	7	24	69
TYR-F												
TYR-F 136-7	18.5	16.0	12840	101.4	32	159	2920	580	250	3	20	62
TYR-F 146-7	24.6	21.4	17130	135.2	42	203	3720	580	250	4	20	63
TYR-F 156-7	30.8	26.7	21410	169.0	53	246	4520	580	250	5	20	64
TYR-F 166-7	36.9	32.1	25690	202.8	63	290	5320	580	250	6	20	65
TYR-F 176-7	43.1	37.4	29970	236.6	74	333	6120	580	250	7	20	66
TYR-F 236-7	22.1	19.3	15410	121.7	42	176	2920	680	250	3	24	65
TYR-F 246-7	29.5	25.7	20550	162.2	53	225	3720	680	250	4	24	66
TYR-F 256-7	36.9	32.1	25690	202.8	65	274	4520	680	250	5	24	67
TYR-F 266-7	44.3	38.5	30830	243.4	76	323	5320	680	250	6	24	68
TYR-F 276-7	51.7	44.9	35970	283.9	88	372	6120	680	250	7	24	69



Defrost Systems

Several forced defrost systems are available. Each defrost system is optimised for specific applications and ambient conditions.

Hot Gas Defrost (G)

The driptray can be fitted with a defrost coil (G) to bring it rapidly up to temperature by means of hot gas.

The following G-system is available :

- G1** *Air on temperature down to - 5 °C.*
Defrost coil under the coil block.

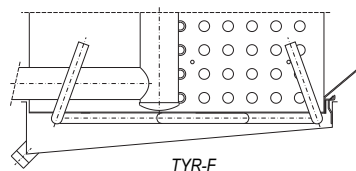
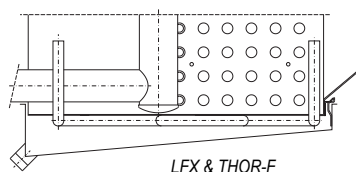

Electric Defrost (E)

Stainless steel heater elements placed in additional tubes between the evaporator tubes. The elements for the driptray are fitted to the bottom of the inner tray. Both coil and driptray have the same elements.

Standard voltage per element 230 V.

Connection to 230 V / 1 phase or 400 V / 3 phase, connected in star with Zero-Wire.

Total defrost power is given for 400 V / 3 phase with Zero-Wire.

All elements can be withdrawn at the refrigerant connection side. The driptray elements can be taken out after removal of the outer tray. The heater elements are pre-wired and are connected to one or more terminal boxes.

Depending on the ambient temperature and air humidity a number of E-executions are available.

- E1** *Air on temperature down to - 25 °C.*
Electric stainless steel defrost elements in the driptray. For use in combination with for example hot gas defrost in the coil block.
- E4** *Air on temperature down to - 5 °C.*
Electric stainless steel defrost elements in the coil block and driptray, low duty.

Water Defrost (W)

- W** Water defrost system for defrosting in the temperature range to -20 °C.

Defrost power

Cooler type	Elements article number	E1		E4		cap. kW
		nr of elements	cap. kW	nr of elements coil	tray	
LFX						
136	33.05.19	1	1.4	2	1	4.2
146	33.06.50	1	2.3	2	1	6.9
156	33.05.21	1	3.2	2	1	9.6
166	33.06.53	1	3.6	2	1	10.8
246	33.05.21	1	3.2	2	1	9.6
256	33.05.22	2	4.0	4	2	12.0
266	33.07.68	2	4.2	4	2	12.6
276	33.07.34	2	5.5	4	2	16.5
286	33.07.69	2	5.2	4	2	15.6
THOR-F & TYR-F						
136	33.03.39	2	6.0	3	1	11.9
146	33.03.45	2	7.9	3	1	15.8
156	33.03.52	4	9.8	6	2	19.6
166	33.03.58	4	11.7	6	2	23.4
176	33.03.63	4	13.6	6	2	27.3
236	33.03.39	2	6.0	4	1	14.9
246	33.03.45	2	7.9	4	1	19.7
256	33.03.52	4	9.8	8	2	24.5
266	33.03.58	4	11.7	8	2	29.3
276	33.03.63	4	13.6	8	2	34.1



Dimensions LFX

Cooler model	Dimensions (mm)					
	A	B	C1	C2	D1	D2
LFX 136-7	1600	450	1350	–	800	–
LFX 146-7	2040	450	1790	–	1020	–
LFX 156-7	2560	450	2320	–	1280	–
LFX 166-7	2900	450	1345	1315	790	1320
LFX 246-7	2660	540	2320	–	1330	–
LFX 256-7	3420	540	1860	1240	860	1700
LFX 266-7	3640	540	1660	1660	970	1710
LFX 276-7	4190	540	2205	1660	1050	2080
LFX 286-7	4740	540	2205	2205	1270	2200

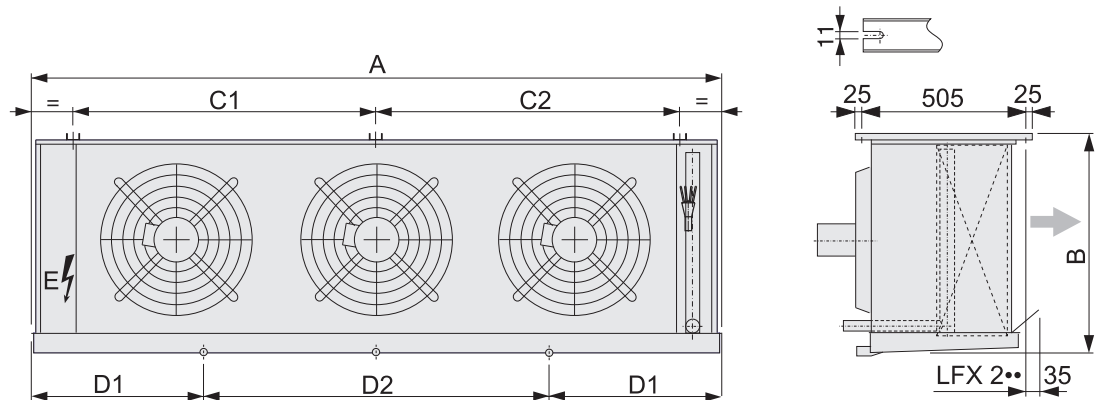

Refrigerant connections

Type	LFX	
	inlet	suction
136-7	½"	22 mm
146-7	½"	22 mm
156-7	½"	22 mm
166-7	5/8"	28 mm
176-7	–	–
236-7	–	–
246-7	½"	28 mm
256-7	5/8"	35 mm
266-7	5/8"	35 mm
276-7	5/8"	35 mm
286-7	5/8"	35 mm

Note: refrigerant connections for THOR-F/TYR-F are calculated in the selection software.



Dimensions THOR-F & TYR-F

Cooler models	Dimension B (mm)
THOR-F / TYR-F 1**	580
THOR-F / TYR-F 2**	680

Refrigerant connections THOR-F & TYR-F: see page 9.

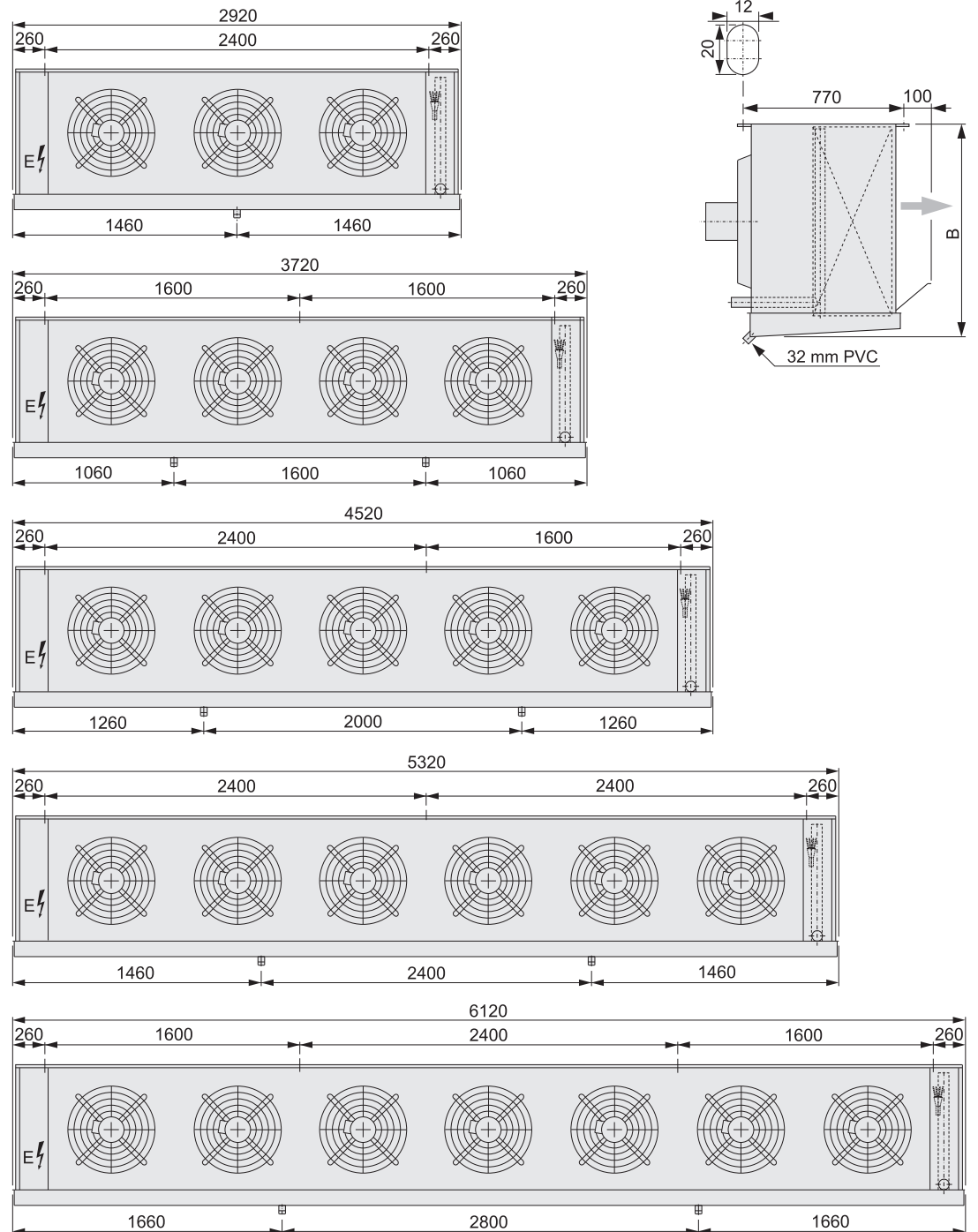

Changes possible without prior notice

Alfa Laval in brief

Alfa Laval is a leading global provider of specialized products and engineered solutions.

Our equipment, systems and services are dedicated to helping customers to optimize the performance of their processes. Time and time again.

We help our customers to heat, cool, separate and transport products such as oil, water, chemicals, beverages, foodstuffs, starch and pharmaceuticals.

Our worldwide organization works closely with customers in almost 100 countries to help them stay ahead.

How to contact Alfa Laval

Up-to-date Alfa Laval contact details for all countries are always available on our website at www.alfalaval.com